

Halsey Taylor®

Installation/Care/Use Manual

Hydroboost In Wall Bottle Filling Station

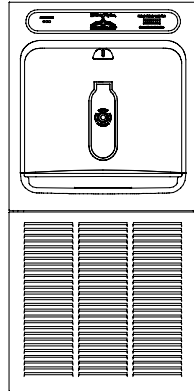

HTHB-8*
HTHB-8-NR*

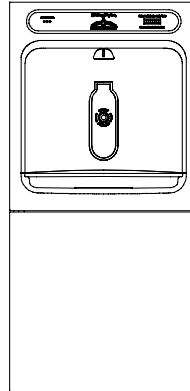

HTHB_LR*
HTHB_LR-NR*

Installer

To assure you install this model easily and correctly, PLEASE READ THESE SIMPLE INSTRUCTIONS BEFORE STARTING THE INSTALLATION. CHECK YOUR INSTALLATION FOR COMPLIANCE WITH PLUMBING, ELECTRICAL AND OTHER APPLICABLE CODES. After installation, leave these instructions inside the fountain for future reference.

IMPORTANT

ALL SERVICE TO BE PERFORMED BY AN AUTHORIZED SERVICE PERSON

IMPORTANT! INSTALLER PLEASE NOTE.

THE GROUNDING OF ELECTRICAL EQUIPMENT SUCH AS TELEPHONE, COMPUTERS, ETC. TO WATER LINES IS A COMMON PROCEDURE. THIS GROUNDING MAY BE IN THE BUILDING OR MAY OCCUR AWAY FROM THE BUILDING. THIS GROUNDING CAN CAUSE ELECTRICAL FEEDBACK INTO A FOUNTAIN, CREATING AN ELECTROLYSIS WHICH CAUSES A METALLIC TASTE OR AN INCREASE IN THE METAL CONTENT OF THE WATER. THIS CONDITION IS AVOIDABLE BY USING THE PROPER MATERIALS AS INDICATED. ANY DRAIN FITTINGS PROVIDED BY THE INSTALLER SHOULD BE MADE OF PLASTIC TO ELECTRICALLY ISOLATE THE FOUNTAIN FROM THE BUILDING PLUMBING SYSTEM. WE SUGGEST THAT THE BOTTLE FILLER BE PROTECTED BY A GROUND FAULT CIRCUIT INTERRUPTER (GFCI)

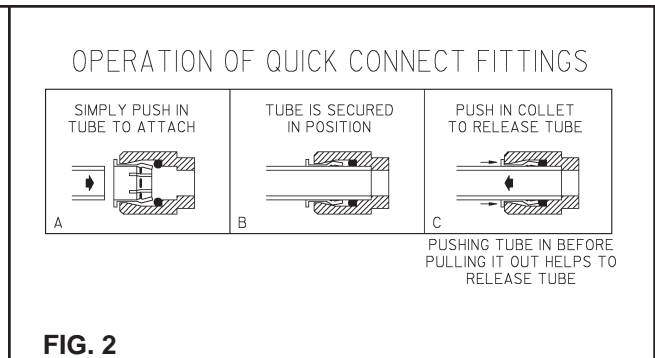
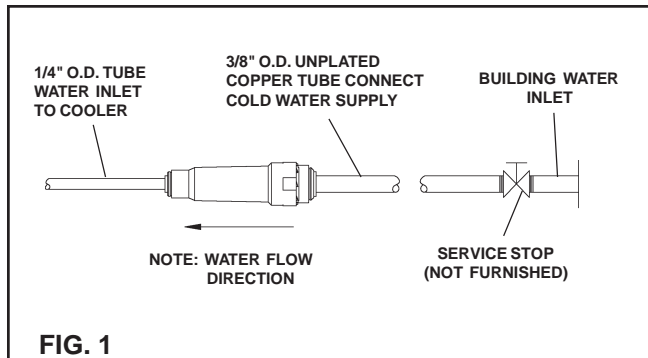

HTHP-8*, HTHB-LR*, HTHP-8-NR*, HTHB-LR-NR* ROUGH IN

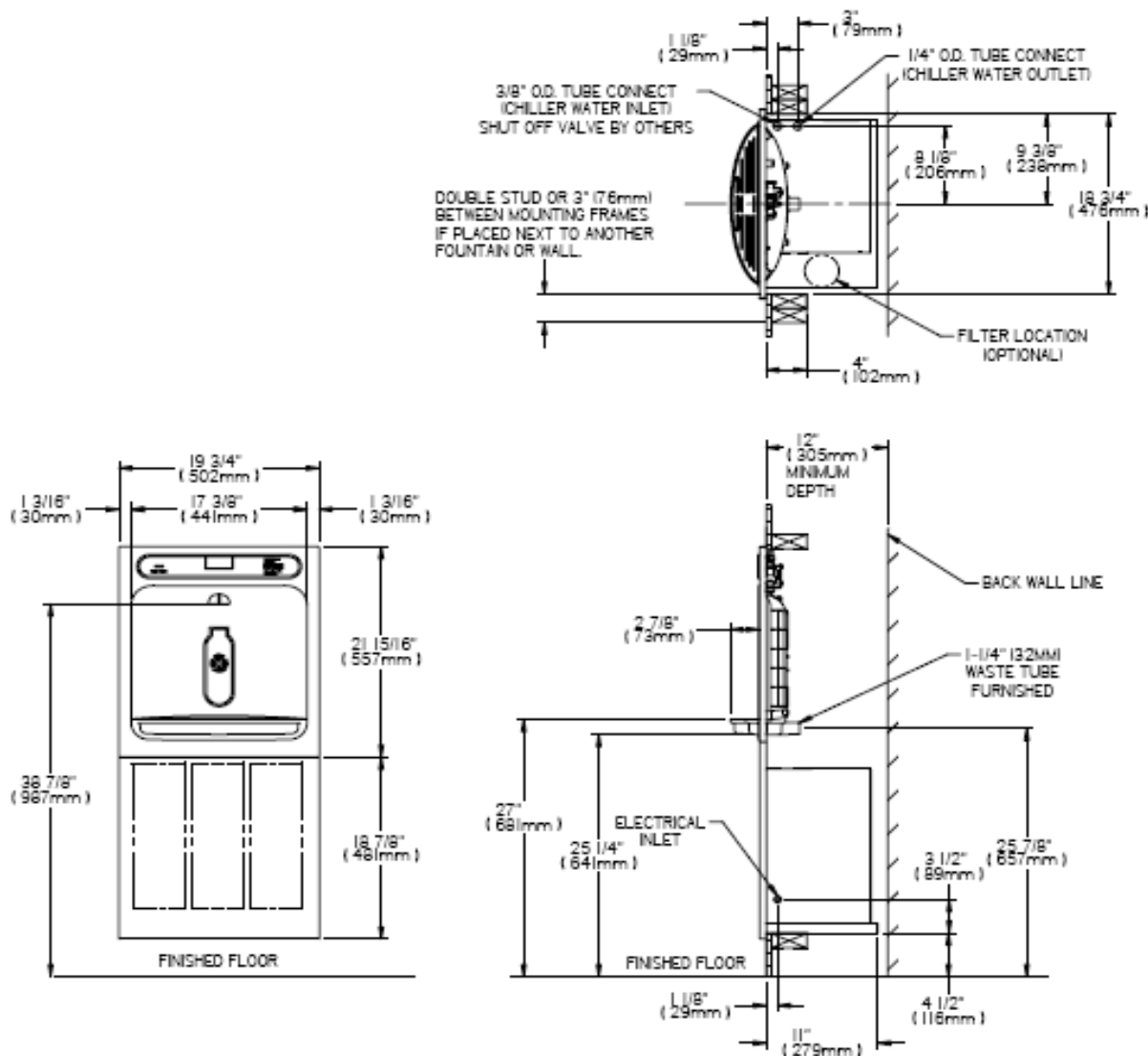

FIG. 3

INSTALLATION INSTRUCTIONS

1. Install mounting frame. See mounting frame instructions.
2. Install remote chiller. See chiller instructions.
3. **EWF3000 WATERSENTRY PLUS FILTER INSTALLATION**
 (Filtered units only. For non filtered units proceed to step 4b)

NOTICE: Do not use with water that is microbiologically unsafe or of unknown quality without adequate disinfection before or after the system.

1) These filter kits must be installed in compliance with all state and local laws and regulations governing the installation and use of this product. Maximum inlet water temperature 100°F (38°C).

2) See filter instructions for filter assembly. Insert 3/8" elbow fitting into the inlet side of filter head, insert 1/4" polytube or 1/4" x 90° elbow into outlet of filter head prior to mounting the filter head assembly into the remote chiller

3) Mount filter head to the side of the remote chiller using the filter mounting bracket and screws supplied.

CAUTION: If supply pressure will ever exceed 100 psi, install a pressure regulator to limit the inlet pressure to the filter to 100 psi or below.

DO NOT ATTACH HOT WATER LINE TO FILTER. To make connections on the filter head, loosen locknut. Push the tube end past both o-rings to a positive stop in the filter head recess - approx. 1", locknut may have to be backed out a little more. Screw the locknut hand tight to seal (See Fig. 5). Ends of tubing must be cut square and free of burrs and sharp ends that could cut or nick the o-rings.

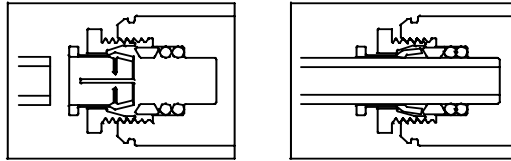

**NOTE: SCREW THE LOCKNUT
 HAND TIGHT TO SEAL
 FIG. 5**

- 4a. Make water supply connections for Filtered units. Install a shut-off valve and union connection to building water supply (valve and union not provided). Turn on the water supply and flush the line thoroughly.
 - 4b. Make water supply connections for Non Filtered units. Install a shut-off valve and union connection to building water supply (valve and union not provided). Turn on the water supply and flush the line thoroughly. Install the in-line strainer between the valve and the cooler. The in-line strainer is not installed on filtered units.
5. (Filtered units only. For non filtered units proceed to step 7)
 Make connection between filter head and building supply line. Insert the 3/8" water line into the inlet side of the filter head by pushing it in until it reaches a positive stop, approximately 3/4" (19mm). Install two 1/4" x 1/4" unions (provided) on the chiller. One on the inlet tube, and the other on the outlet tube.
 6. Make connection between the filter head and the remote chiller. Insert end of 1/4" O.D. poly tubing from the filter head (provided) into union on chiller inlet
 7. Mount the upper panel to the mounting frame, aligning holes in the hinge brackets with holes in the mounting frame (three places). Mount with adequate size screws (Not provided) Close the door and verify that the lock brackets on the side and bottom of the panel align with the slots on the mounting frame. Also verify that the panel is hanging high enough that it covers the top of the mounting frame. If adjustments need to be made, open the door and loosen the three screws on the hinge and adjust accordingly and then retighten the screws.
 8. Connect water line from the water station by inserting the 1/4" O.D. poly tubing into the union on the chiller outlet.
 9. Close the upper door and attach the drain fittings to drain tube. Re-attach elbow to p-trap and cut waste tube to required length using plumbing hardware and trap as a guide.

**PLUMBING DIAGRAM
 FIG. 6**

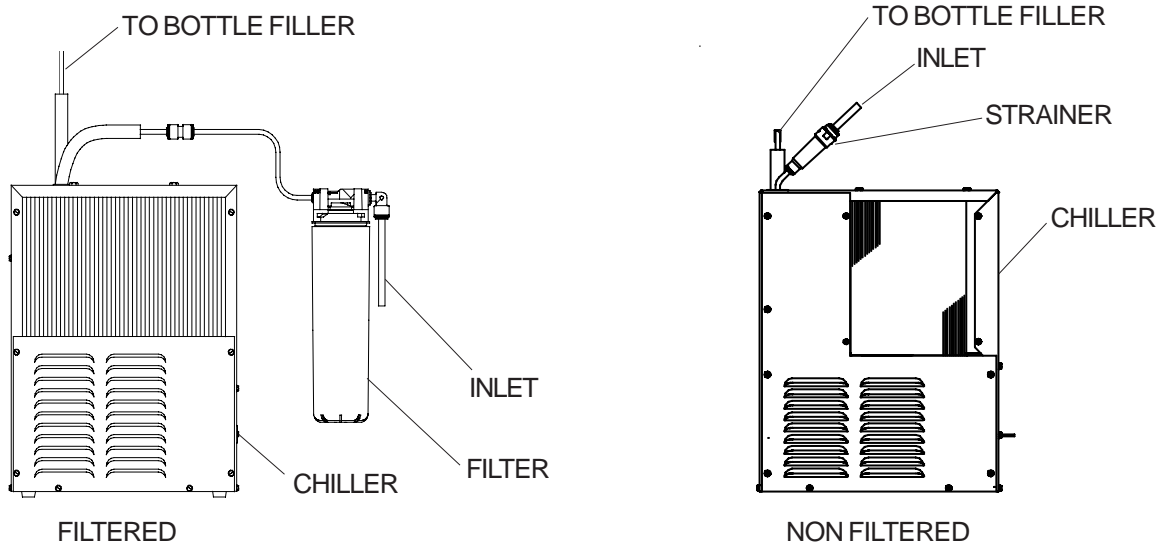

10. Lock the door in place using two set screws (provided) on the side of the panel, and a ¼ x 20 bolt thru the front of the panel into the nut in the frame.
11. (Filtered units only) Install filter cartridge, remove filter from carton, remove protective cap, attach filter to filter head by firmly inserting into head and rotating filter clockwise.
12. Turn water supply on and inspect for leaks. Fix all leaks before continuing.
13. Once unit has been inspected for leaks, and any leaks found corrected, plug Bottle Filler into wall (power cord not supplied on 220V models). Be sure to reinstall fuse to the circuit or switch the circuit breaker back to the "ON" position.
- 14a. (Filtered units) Once power is applied to Bottle Filler, the GREEN LED light should illuminate showing good filter status along with the LCD Bottle Counter.
- 14b. (Non Filtered units) Once power is applied to Bottle Filler, the LCD Bottle Counter should illuminate.
15. Verify proper dispensing by placing cup, hand, or any opaque object in front of sensor area and verify water dispenses. Note: the first initial dispenses might have air in line which may cause a sputter. This will be eliminated once all air is purged from the line. A steady stream of water assures all air is removed. The sensor has a 30 second maximum **ON** time. It may be necessary to step away from beam a few times to allow chiller tank to refill. Check for leaks.
16. Mount the lower panel to the mounting frame, aligning holes in the hinge brackets with holes in the mounting frame (three places). Mount with adequate size screws (Not provided) Close the door and verify that the lock brackets on the side of the panel align with the slots on the mounting frame. If adjustments need to be made, open the door and loosen the three screws on the hinge and adjust accordingly and then retighten the screws.
17. Lock the lower door in place using two set screws (provided) on the side of the panel.
18. **SETTING THE CONTROL BOARD – SETTING RANGE OF THE IR SENSOR**

In order to access the programming button, the lower door must be open. The button is located at the bottom of the upper panel

With your finger, depress the program button for approximately 2 seconds until the display changes then release.

The display will change and scroll through three messages:

"RST FLTR" – Reset Filter Status LED

"RST BCNT" – Reset Bottle Count

"RNG SET" – Range Set for IR Sensor

If the program button is not pushed again the display will scroll through the three messages above for three cycles and then default

back to bottle count and be back in run mode.

To set the RANGE of IR Sensor: when display shows "RNG SET" push program button once the display will show current value (can be 1 – 10) i.e. "RNG = 3".

Once display shows current value push the program button to scroll through value of 1 – 10. Select the desired range setting.

Once range is selected allow approximately 4 seconds to pass and then the display will go back to bottle counter and be in run mode.

Test bottle filler by placing bottle or hand in front of sensor to make sure water is dispensed.

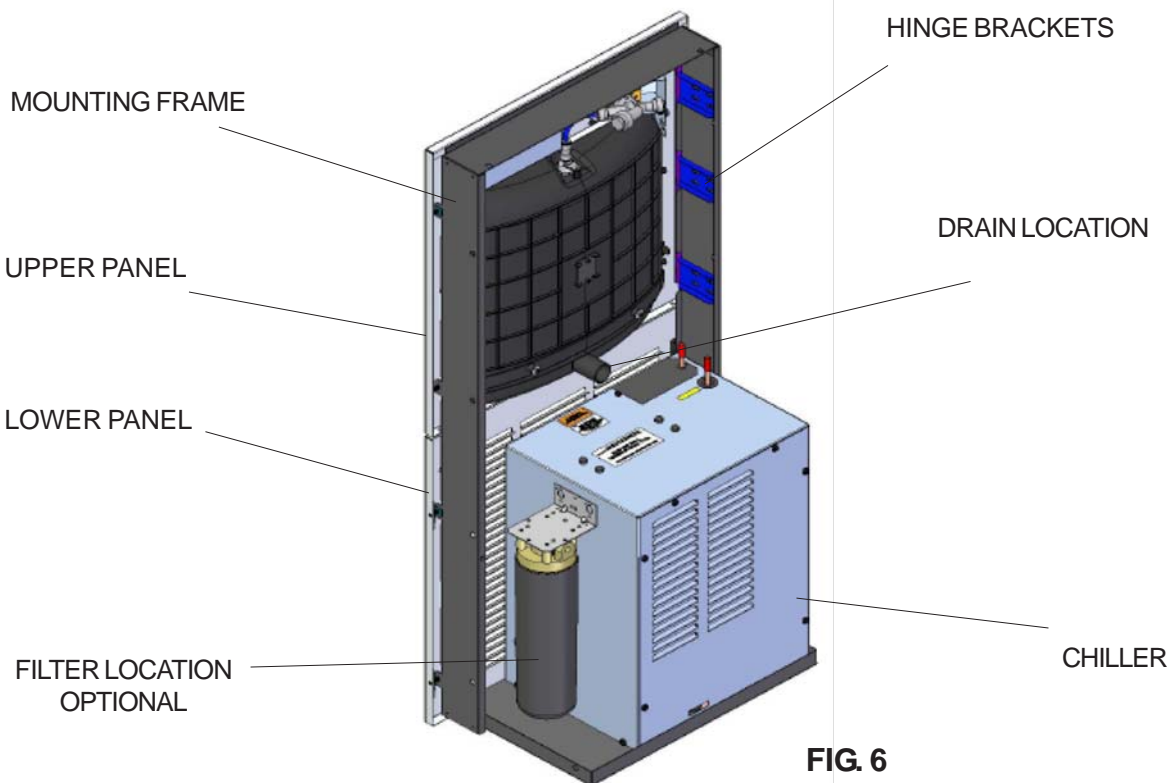

FIG. 6

19. **RESETTING FILTER** (Filtered units only. For non filtered units proceed to step 20)

In order to access the programming button, the lower door must be open. The button is located at the bottom of the upper panel

With your finger, depress the program button for approximately 2 seconds until the display changes then release.

The display will change and scroll through three messages:

“**RST FLTR**” – Reset Filter Status LED

“**RST BCNT**” – Reset Bottle Count

“**RNG SET**” – Range Set for IR Sensor

If the program button is not pushed again the display will scroll through the three messages above for three cycles and then default

back to bottle count and be back in run mode.

When the display changes to "RST FLTR", depress the button again. The display will change to show "FLT=".

Depress the button again and the display will show "FLTR=0". The green LED should now be illuminated indicating that the visual filter monitor has been reset.

20. **RESETTING BOTTLE COUNTER**

In order to access the programming button, the lower door must be open. The button is located at the bottom of the upper panel

With your finger, depress the program button for approximately 2 seconds until the display changes then release.

The display will change and scroll through three messages:

“**RST FLTR**” – Reset Filter Status LED

“**RST BCNT**” – Reset Bottle Count

“**RNG SET**” – Range Set for IR Sensor

If the program button is not pushed again the display will scroll through the three messages above for three cycles and then default

back to bottle count and be back in run mode.

When the display changes to "RST BCNT", depress the button again. The display will change to show current bottle count value i.e. "BC0033183". Depress the button again and the display will change to "BTLCT=0" for approximately 2 seconds and then return to run mode displaying 000000. You can test the bottle counter by running water approximately 5 seconds to see bottle counter advance 1.

WATERSENTRY® PLUS FILTER PARTS LIST (See Fig. 8)			LISTA DE PIEZAS DEL FILTRO (Vea Fig. 8)	LISTE DES PIÈCES DU FILTRE (Voir Fig. 8)
ITEM NO.	PART NO.	DESCRIPTION	DESCRIPCIÓN	DESCRIPTION
1	51294C	Filter Head Assy.	Ensamblado de la Cabeza del Filtro	Ens. de tête de filtre
2	70792C	Screw #8-18 x .75 PH	Tornillo #8-18 x .75 PH	Vis #8-18 x .75 hp
3	70823C	Fitting - Superseal 3/8" (10 mm)	Accesorio - Super sello 3/8" (10mm)	Raccord - Superseal 3/8" (10mm)
4	70822C	Fitting - Superseal 1/4" (6 mm)	Accesorio - Super sello 1/4" (6 mm)	Raccord - Superseal 1/4" (6mm)
5	55898C	Filter Assy	Ensamblado del Filtro	Ens. filtre
6	70818C	Elbow - 3/8" (10mm)	Codo - 3/8" (10 mm)	Coude - 3/8" (10mm)
7	22490C	Bracket	Fijador	Support

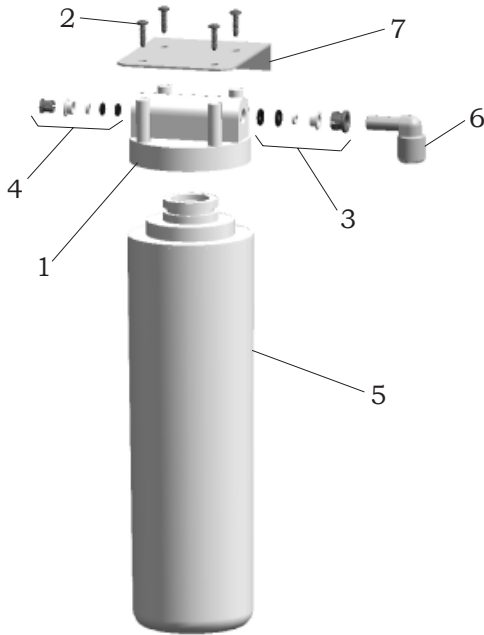

WATER FILTER EXPLODED VIEW

FIG. 7

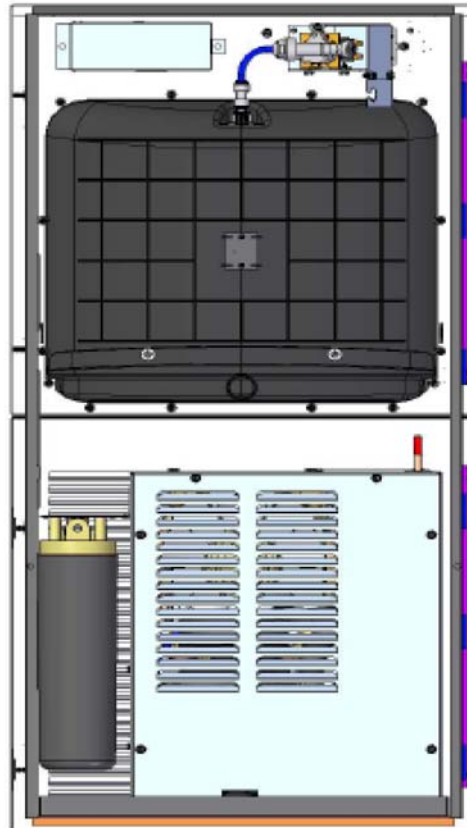

FIG. 8

REPLACEMENT PART KITS

PART NO.	DESCRIPTION
98543C	Kit - Electrical Package
98544C	Kit - EE Sensor
98545C	Kit - Solenoid Valve Replacement
98546C	Kit - Aerator Replacement
98549C	Kit - Hardware & Waterway Parts
98631C	Kit - Electrical Package 220V
98632C	Kit - Solenoid Valve Replacement 220V

Halsey Taylor®

2222 CAMDEN COURT
 OAK BROOK, IL 60523
 630.574.3500

PRINTED IN U.S.A.

FOR PARTS CONTACT YOUR LOCAL DISTRIBUTOR OR VISIT OUR WEBSITE WWW.HALSEYTAYLOR.COM

PARA PIEZAS DE REEMPLAZO PÓNGASE EN CONTACTO CON SU DISTRIBUIDOR LOCAL O VISITE NUESTRO SITIO DE WEB WWW.HALSEYTAYLOR.COM
 POUR VOUS PROCURER DES PIÈCES, CONTACTEZ VOTRE DISTRIBUTEUR LOCAL OU VISITEZ NOTRE SITE WEB A L'ADRESSE WWW.HALSEYTAYLOR.COM